

## Mid Power Luminaire Range - Installation Guide



Zone 1 and 21 Variant CML21ATEX3317 & IEC Ex CML21.0037 or CML21UKEX3319 Zone 2 and 22 Variant CML21ATEX3320 & IEC Ex CML21.0038 or CML21UKEX3321

This installation guide provides instructions for installing the RM Highbay/ Floodlight series of explosion protected floodlights.

### Overview

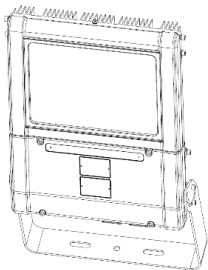

- 1 Safety Instructions
- 2 Installation
- 3 Maintenance
- 4 Technical Specification
- 5 Trouble Shooting

### Important information

The RM series of explosion protected floodlights/highbay are specialist devices, certified for use in specific operating environments.

The units must be installed in accordance with these instructions, must be correctly certified for the specific operating environment and must be installed by suitably qualified personnel.

If you have any queries about the installation or the certification of the unit – please contact Nemalux for immediate assistance and advice.

# 1. Safety instructions

1. Read this leaflet carefully before commencing to install the RM unit and retain it for future use. Installation can only be carried out by suitably qualified personnel.
2. Check the certification and "T" rating to ensure that the mains supply and the ambient temperature present is suitable for the unit being installed.
3. If the RM unit is to be installed in areas of high vibration, please consult with Nemalux.
4. Externally the RM unit housing is constructed from marine grade aluminium, and toughened glass, stainless steel brackets/fasteners and silicone gaskets, internally there are many non metallic components. The end user must ensure that these materials are suitable for the environment the RM unit will be installed in; Zone 1 and Zone 2 Hazardous areas.
5. Check certification nameplate on front of floodlight to ascertain type of threaded cable entry on the luminaire. Select suitably certified ATEX/IEC Ex /UKEX cable glands and stopper plugs, these must be parallel thread, have a minimum of 5 full thread engagement and be of a medium/fine tolerance to ISO965-1 and ISO965-3. The cable entry devices selected must maintain the IP rating of the luminaire.
6. The incoming mains cable should not exceed a temperature rise of 27°C above the ambient conditions; select suitable cable.
7. When the unit is installed correctly and in accordance with these installation instructions it will not harm humans or animals.

## Eye Safety :

Caution – EN62471 Risk Group 2 Classification - The luminaire should be positioned so that prolonged staring into the luminaire at a distance closer than 0.230m is not expected



Isolate mains before  
removing cover



Install in a well  
ventilated area



## 2. Installation

### Mounting RM Unit

1. To meet the requirements of certification a **MINIMUM** of 2 fixing points must be used, the fixing points must be suitable for the conditions of use.
2. The line diagrams below are for guidance only – units may be mounted in any orientation

#### Mounting MP RM Unit – Floodlight Application

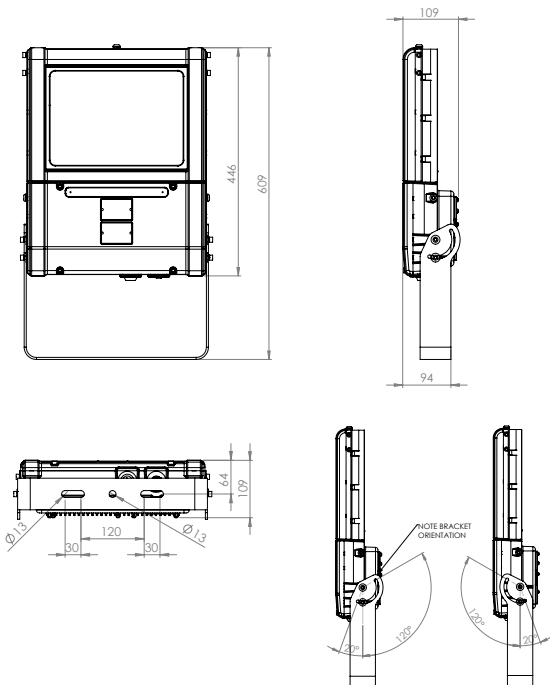

## Mounting RM Unit – Highbay Application

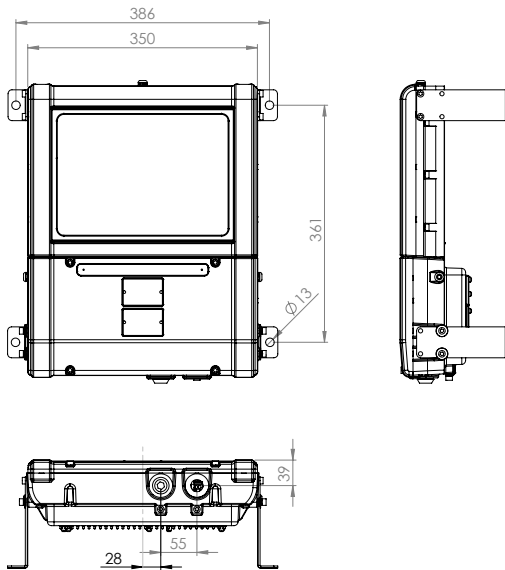

## Typical wiring diagram

WIRING Z1 & Z2

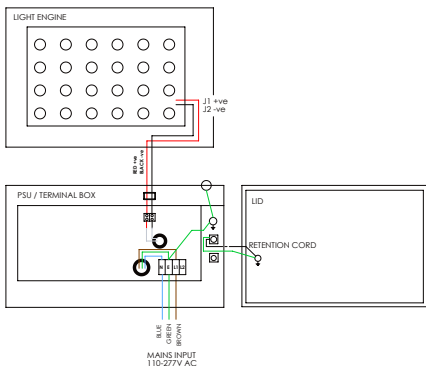

Wire the Mains cable into the terminal block. Provision has been made for this and identified as the E (Earth), L1 (Switched Live), L2 (permanent live) and N (Neutral) terminals. There are two pairs of contacts for each of these to facilitate a mains cable that can be looped in and out of the unit. The L2 terminals on a standard unit are not electrically connected but allows them to be used on the same circuits as *emergency units*.

3. Attach mounting brackets as required with M6 screws/washers provided. Tighten to 10Nm. (see Bracket Orientation Diagram)
4. Open terminal block enclosure.
5. Installer should earth the unit separately – an internal and external earth point are provided as standard.
6. Connect wires to mains supply.
7. If the unit is to be opened for any reason, disconnect mains.
8. All RM floodlights/highbay have terminal blocks suitable for looping 4mm<sup>2</sup> cable, only one cable should be connected to each terminal block connection –when incoming cables are installed a creepage and clearance of 5mm and 4mm respectively.
9. Ensure no cables are trapped and gasket is seated correctly and replace terminal cover, tighten to 4Nm
10. If carrying out Insulation Resistance tests the normal method of insulation testing is to connect Live and Neutral together and test between this point and Earth to prevent the risk of damage to the electronic control gear.



### 3. Maintenance

1. It is essential that all RM units are maintained in accordance with the requirements of the EN60079-17 standard: (Electrical apparatus for explosive gas atmospheres – other than mines).
2. **IMPORTANT.** No modifications are permitted to the unit, all spare parts must be purchased from the manufacturer, unauthorized modifications or spare parts will invalidate certification and make the equipment dangerous.
3. Isolate the RM unit from the mains supply and allow to cool before carrying out any maintenance work.
4. The unit has one power supply; in the event that a power supply needs to be replaced remove the terminal enclosure cover to get access to the power supply. Remove the power supply from the mains terminals then remove LED wires (white and white with red mark).
5. Disposal of packaging, RM units and old LED assemblies/power supplies should be carried out in accordance with national regulations.

### 4. Troubleshooting

1. Ensure the two LED boards are correctly wired to terminal block. White/Red to White/Red : White to White – paired cables.
2. Ensure Mains input is correctly connected.
3. Ensure Mains Input is turned on at the source.

#### PROTECTION/CERTIFICATION

PROTECTION/CERTIFICATION – ZONE 1/21 VARIANTS

CML21ATEX3317 or IEC Ex CML21.0037 or CML21UKEX3319 II 2

GD Ex eb mb IIC T4 Gb

Ex tb IIIC T90°C Db

Ta -40°C to +60°C

IP66/IP67 110-277V AC

PROTECTION/CERTIFICATION – ZONE 2/22 VARIANTS

CML21ATEX3320 or IEC Ex CML21.0038 or CML21UKEX3321 II 3

GD Ex ec mc IIC T4 Gc

Ex tc IIIC T90°C Dc

Ta -40°C to +60°C

IP66/IP67 110-277V AC



## 4. Technical Specification

	60W version	120W version
Input Voltage	110-277V AC	
Input Current (230Vac, full load)	0.26A	0.52A
Consumption	60W	120W
Power Factor (230Vac, full load)	>0.97	
Mains Frequency	50/60Hz	
Inrush Current ( $I_{peak}$ @50%)	53A, $\Delta t < 300\mu s$	
Total Harmonic Distortion (230Vac, full load)	$\leq 10\%$	
IP Rating	IP66/67	
Weight (std)	13.2Kg	13.2Kg
Dimensions	See previous pages for line diagrams	
ATEX and IECEx and UKEX Rating	See page 6	

### Inrush Current Typical Curve

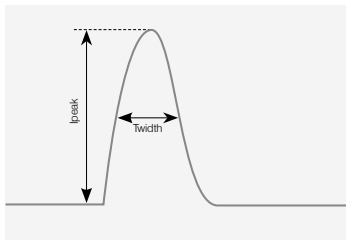

MCB Type	Rating	RM15 (120W Version)
B	10A	4
B	16A	10
B	20A	12
B	25A	15
C	10A	8
C	16A	16
C	20A	20
C	25A	26



# Declaration Of Conformity With The Atex Directive 2014/34/EU & UK Directive SI 2016 No. 1107 (as amended)



The RM series luminaire is manufactured by Raytec Ltd. for Nimalux Inc. Raytec Ltd. declares under our sole responsibility that the product(s) listed below conform with the relevant provisions of directive 2014/34/EU of 20<sup>th</sup> April 2016 and UK Directive SI 2016 No. 1107 (as amended)

Manufacturer	Raytec Ltd Unit 15, Wansbeck Business Park Rotary Parkway Ashington Northumberland NE63 8QW United Kingdom
Description of Equipment	Spartan range of Mid Power Floodlights
Certification Body	CML New Port Road Ellesmere Port CH65 4LZ
Certificate numbers	CML21ATEX3317 or IEC Ex CML21.0037 or CML21UKEX3319 CML21ATEX3320 or IEC Ex CML21.0038 or CML21UKEX3321 ATEX Quality Assurance Notification CSA BV (2813) UKCA Quality Assurance Notification CSA UK (0518)
Equipment Marking	II 2 GD Ex eb mb IIC T4 Gb Ta -40°C to +60°C Ex tb IIIC T90°C Db Ta -40°C to +60°C IP66/IP67 110-277V AC  II 3 GD Ex ec mc IIC T4 Gc Ta -40°C to +60°C Ex tc IIIC T90°C Dc Ta -40°C to +60°C IP66/IP67 110-277V AC





Compliance with the Essential Health and Safety Requirements has been assessed by reference to the following harmonised/designated standards -

EN 60079-0 : 2018

EN60079-7 : 2015 + A1 2018

EN 60079-18 : 2015 + A1 2017

And also 2014/35/EU - Low Voltage Directive, 2014/30/EU - EMC Directive

Signed



Name  
Position

Barry Thompson  
Director

Dated

Serial number





Industrial LED Lighting designed to solve harsh and hazardous lighting challenges.

1018 - 72nd Ave NE | Calgary, AB, Canada T2E 8V9

Toll Free: 1-877-NEMALUX / 1-877-636-2589

P: 1.403.242.7475

F: 1.403.243.6190

E: [info@nemalux.com](mailto:info@nemalux.com)

W: [www.nemalux.com](http://www.nemalux.com)



MADE IN UK

[www.nemalux.com](http://www.nemalux.com) |

[sales@nemalux.com](mailto:sales@nemalux.com) |

Tel 403-242-7475 |

Fax 403-243-6190

10-10

SUBJECT TO CHANGE WITHOUT NOTICE